

## DINGS

Freno, frenos. Serie 40, 50, 60, 70, 80, 90, doble c-face, washdown. Todos estos frenos operan con corriente AC. Cubriendo una amplia gama de usos, los frenos del disco magnético de Dings tienen grados del esfuerzo de torsión el extenderse a partir de la 3/8 a 450 libras. Pies. Los tamaños están disponibles para caber todos los motores de cara nema C con 405TC. El sistema de resorte, con lanzamiento electromagnético. Los frenos Dings se diseñan para los transportadores, open doors, drive machine, las grúas, y una multiplicidad de otros usos que requieran energía que para y que sostiene cargas.

### FRENOS ELECTRICOS DINGS DE LA SERIE 60, 70 & 80



PARTES DINGS

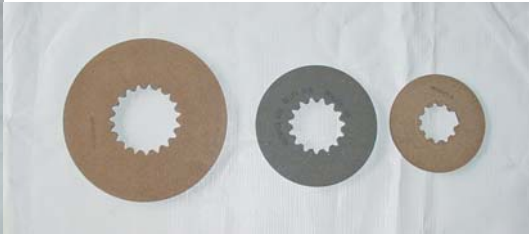

DISCO DE FRICCION 80, 70, 60 SERIES



STUD FOR 1, 2, 3, 4, FRICTION DISC



FRENO 70

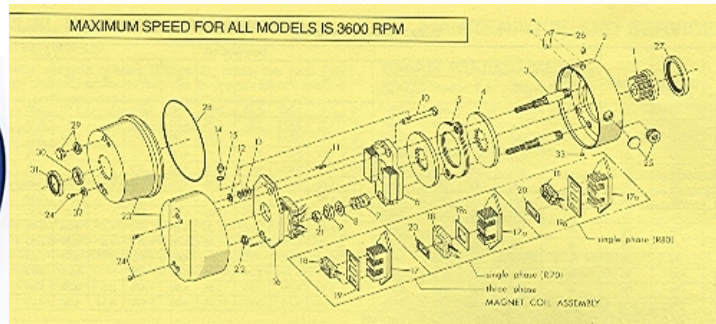

PARTES DE LA SERIE 70 & 80 SERIES



DOUBLE C-FACE

Estos frenos eléctricos son 230, una sola fase o 230, 460 vac tres fases



## DODGE

Reductores, motorreductores, chumaceras, bujes, reductor, reeves, tigeat, quantis, maxum, apg, Master XL, ciclone, ultima, motorreductor de bajas capacidades a altas capacidades de torque.

Reducer, reducers, gearmotor, gearbox,



Torque arm II



Torque-arm



Torque armT



Hydroil



Quantis



Maxum



Tigear-2



Dodge Tigear



APG



Master XL



Ultima



Reeves Pulley



Reeves Motodrive



Ciclone



CST

## DYNACORP

Frenos, embragues, freno, embrague, clutch, wrap spring, clutch-brake coupling, freno con flangia, montaje al piso. Controles para freno/clutch Dynatec 2800, 2950, 2700, 2750, 2500, 2550, D2100, D2110, D2101, D2111, D2015, 2015, 2023, 2016, 2601, 2400, Instrumentos para medir momentos de inercia. Freno/embrague electromagneticos, frenos por resorte, frenos para motor en motores AC, freno/embrague wrap spring.



Clutch/freno control "Dynatec"



Sheave clutches



Freno/embrague montaje al piso



Freno/embrague



Freno montado en ejes



Frenos por resorte



Clutch & Clutches Couplings

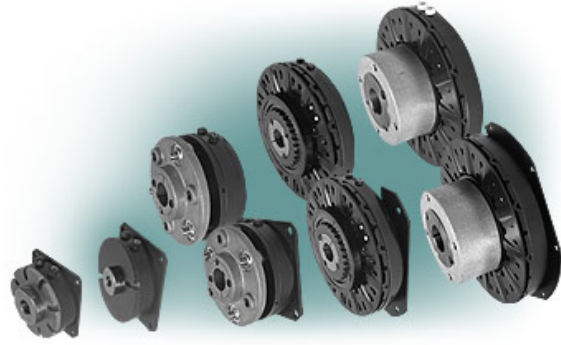

Frenos montados con flangia

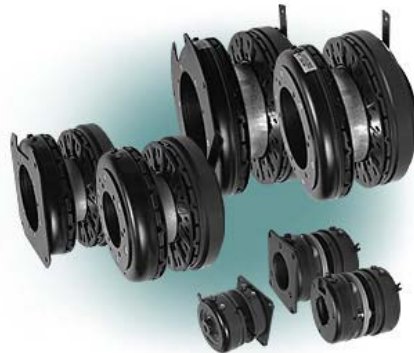

Clutch/Freno couplings



Wrap Spring solo clutch o clutch/freno